



Micromountaineers, Old and New

(6M, 20M, and 30 M info, and a newer 7 MHz version. [Scan to the end for info on Increased Power.](#))

Updates: 13June01, 19Jan04, 25March04, 6June05, 24Sept06,10Jan07.

The July 2000 QST included an update paper titled "The Micromountaineer Revisited" where we expanded the original 1973 idea to include other bands. Of special interest are the higher frequency bands reached with third overtone crystals. Terry White, K7TAU, was the co-author on this paper. (Terry does most of our circuit board layouts.) The bottom rigs in the above photo are for 28 MHz (blue, left) and 7 MHz (right.) The upper box is the original Micromountaineer from 1973.

The folks at ARRL gave us permission to put the original schematic diagrams up on the web. The 28 MHz unit, which is the first one we built is shown below:

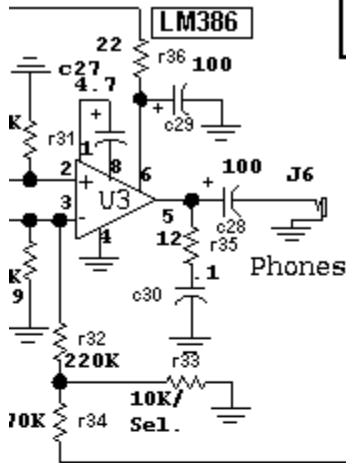

Note: Parts in schematic are for 28 MHz. 7 MHz parts in chart to right.

7 MHz Band-Specific Parts

- L1,2: 15uH RFC
- L3: (PA) 22t#26, T37-2
- L4: (PA) 19t#26, T37-2
- L5: (mixer) 22t#28 T37-2
- C1: (offset) 82pF
- C2: (xtal osc) 390pF
- C3: (xtal osc) 100 pF
- C13: 360 pF
- C14: 820 pF
- C15: 470pF
- C19: (mixer) 180pF
- C18: (mixer) 56pF
- T1: 30t#28 T37-2, 4t#22 Link.
- T2: 4t#28 or smaller primary, 1t#22 secondary, ferrite balun core, BN-43-2402. See Fig.2.

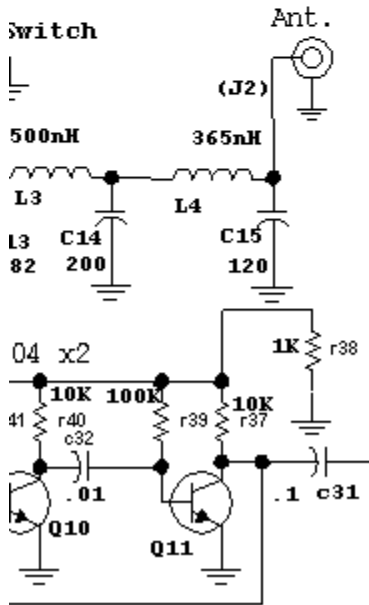

**uM7-99
7 MHz CW Transceiver
w7zoi feb00**

- C4,20: 4.5 to 65pF, Digikey SG3009-ND
- C90: 390 pF
- C12: 33 pF 5% fixed NPO
- R14: 47 for 600 mW
- update: 8Feb00 wh

We will not go through any circuit description here, for it is all in the original QST paper. The material that follows is generally an expansion of that information. That is, the QST paper presented the design, ready for duplication. The material that follows presents information for other bands, and talks about how we did some of the design.

The printed circuit boards are available from Kanga USA. Click here on [Kanga](#) to see their web site. They also have components for the 1999 Version of the Micromountaineer. But this is not a kit. That is, Bill is assisting the

builders by supplying critical components, but supplies no resistor-by-resistor instructions. Nor does he guarantee success. The builders are on their own to treat this as a "homebrew" project, assuming the commitment that goes with such an effort. The first of the "commercial" boards to be turned on happened without a hitch and is shown below. This one was built for the 14 MHz band.

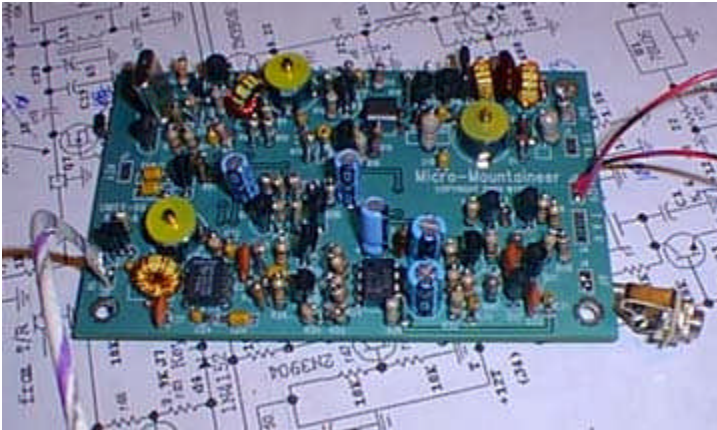

There is no need to use a printed board if you don't really wish to do so. The alternative, and one that we heartily recommend, is a breadboard, shown below. This is the original 28 MHz version during development.

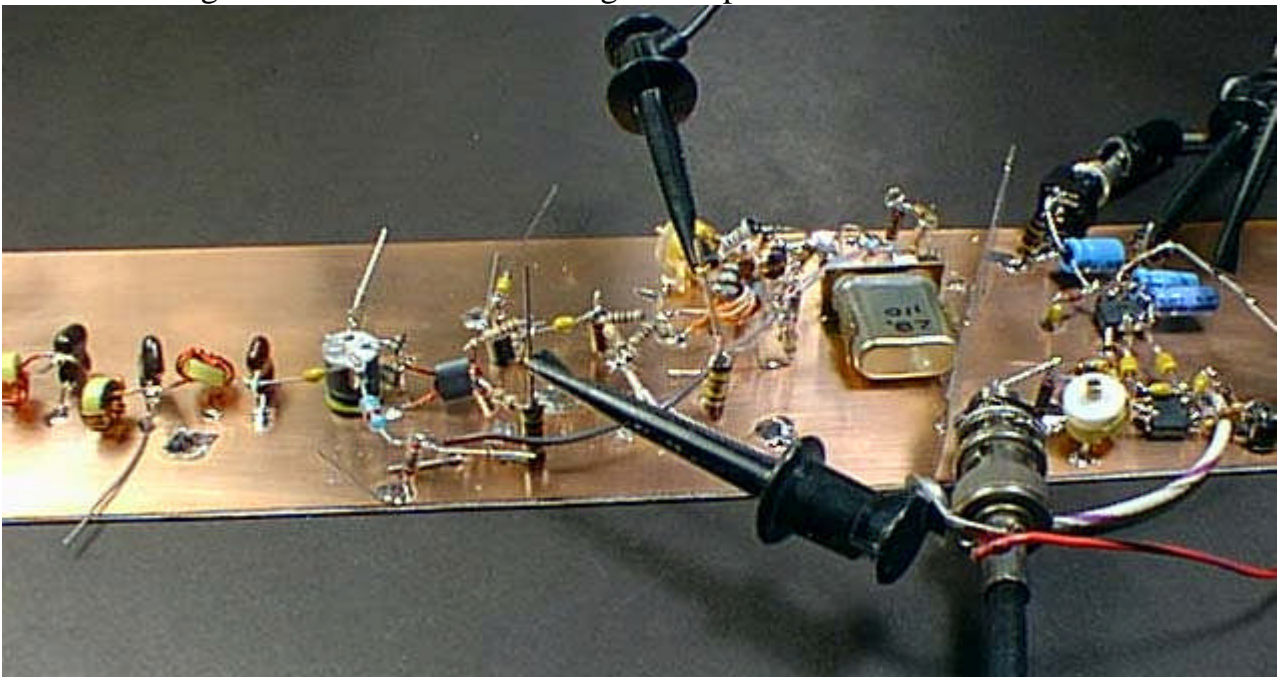

This version used a 2N3866 PA and had a 7th order low pass filter in the output. (Count the low pass filter components.) We switched parts later. We actually made contacts with this rig, even though it was less than convenient. But one could solder another strip to this one to form a "front panel" and have

something that is more functional. There is no performance difference between the final printed board and this extremely ugly version.

A variety of construction methods are popular for breadboards. This information is found in EMRFD, p1.2.

Signal Levels

The following RF levels were measured on the 7 MHz version that appeared in QST. The measurements were performed with a Tektronix 453A1 60 MHz oscilloscope with a YT5060 probe in the 10X position. The measurements used AC coupling, so only the signal level is represented and not the DC components. These are the transmitter measurements:

T1 output, key up: 2.7 v pk-pk

Q3 base, key down: 1.7 v pk-pk.

Q3 collector, key down: 15.8 v pk-pk. clipped on negative edge.

Q5/Q6 base, key down: 3.8 v pk-pk, clipped on the top.

Q5/Q6 collector, key down: 24 v pk-pk. Clean.

Output across 50 Ohm Terminator: 16 v pk-pk. (640 mW output)

These levels are merely representative of what we were seeing. We recommend that you build the transmitter strip in a stage-by-stage sequence as outlined in the text.

Designing for Other Bands

The procedure used to obtain values for the output filter is illustrated with the 30 meter band. We start by designing a doubly terminated Chebyshev low pass filter with a ripple cutoff of 10.4 MHz. (11.8 MHz 3 dB cutoff) The output from L.exe, a program on the disc with Introduction to Radio Frequency Design (ARRL, 1994) is shown below. (A similar program, in Microsoft Windows, is available on the CD accompanying Experimental Methods in RF Design.) The capacitor values are close to standard values of 360 pF and 600

pF. We can always parallel capacitors to obtain non-standards. During the filter design, we can alter the ripple value (here 0.1 dB) and the cutoff frequency to get values close to standard.

```

L
R-load = 50.000      Ripple = 0.100000 dB.  Order = 5
Cutoff freq. = 10.400 MHz.
Max passband ref.coef.= 0.150873      Min.Ret.Loss = 16.43 dB.
-----
Low Pass Filter (Shunt C and series L.)
-----
C<1> = 351.002 pF          G<1> = 1.1468
L<2> = 1049.208 nH.       G<2> = 1.3712
C<3> = 604.484 pF        G<3> = 1.9750
L<4> = 1049.208 nH.       G<4> = 1.3712
C<5> = 351.002 pF        G<5> = 1.1468

3-dB cutoff/Ripple cutoff ratio = 1.1347
...press a key to continue...

```

Next we examine the input impedance with a Smith Chart. We have set the computer program up for a 1 to 20 MHz sweep with a major dot at 10.1 MHz. The filter now uses the standard capacitors and inductors of 1.05 uH, values which we could wind on toroids. The impedance seen looking into the terminated filter is right at the center of the chart, very close to a pure 50 Ohms.

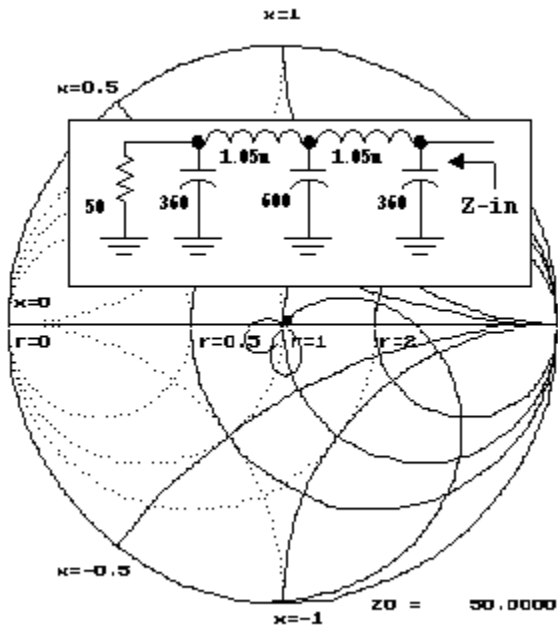

For an output of about half a watt with reasonable efficiency, we want the PA collector to see an impedance of about 100 Ohms with minimal reactance. We could insert a matching network or we can adjust the existing low pass filter to produce this value. The capacitor and inductor closest to the collector are adjusted until the 10.1 MHz impedance "seen" by the collector is close to the desired value, shown below.

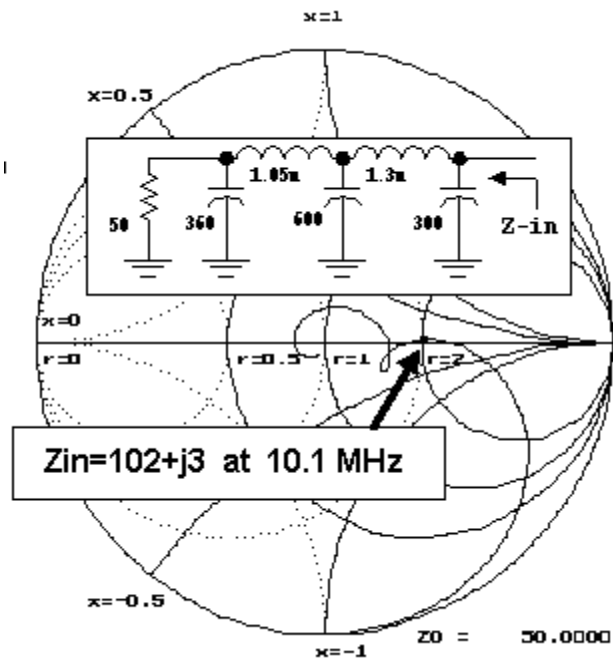

The final filter uses a 300 pF capacitor and a 1.3 uH inductor next to the collector. The reactance of these elements can be calculated at 10.1 MHz to generate a normalized filter that can now be used for any band, shown below.

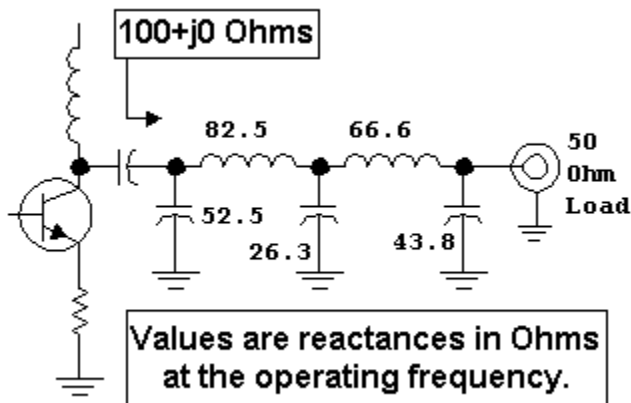

Any Smith Chart program can be used for calculations of this sort such as

ARRL's Radio Designer. We used MicroSmith. One could even do it on paper! The Smith Chart is not just an antenna tool.

Why 0.5 watt output?

Many prospective builders of the Micromountaineer ask why the 0.5 watt output power level was chosen. Many of the popular rigs run a bit more power. Our choice was not random. Rather, it is a power that we have found to be a good compromise for portable operation where the station is carried in a rucksack. A transceiver running half a watt output will operate from a string of AA cells for a considerable time period. Yet, it is enough power that it will consistently produce contacts, even with modest antennas.

A complete station, including batteries, key and antenna, can be assembled with a total weight of two or three pounds (assuming a tree supports the antenna.) More power will be more effective with contacts, but the batteries will not last as long. Deciding which power is best for you is a set of experiments that we urge you to perform. The half watt level has worked well for us while backpacking in the Pacific Northwest.

Many of you may want more power, while a few may be willing to use less. We encourage you to make changes. After all, it's not a kit.

Update: Since this was originally written, we have investigated some battery alternatives. See Chapter 12 of Experimental Methods in RF Design.

Remember that the battery ratings shown are for optimum discharge conditions. The energy capacity drops considerably with decreasing temperature.

Is the 2N3904 up to the challenge?

The Micromountaineer uses a single transistor type throughout whenever an NPN is needed. The 2N3904 is an excellent transistor with a 300 MHz FT and Beta that holds up well at high currents. It's both cheap and readily available, at least in North America. A pair was used in parallel for the power amplifier.

A TO-92 2N3904 transistor is rated for a collector dissipation of 0.625 watt. This is the power that the transistor can handle with a junction temperature of 25 degrees C. The maximum rated power drops linearly with temperature from

625 mW at 25 ° C to 0 at 150 ° C. The uM transceiver uses two 2N3904s in parallel, so we can double the allowed power dissipation to 1.25 watt at 25 ° C.

Quoting a single number for power dissipation at a low (typically "room") temperature is really a poor representation of a transistor, for the allowed dissipation is always a function of temperature. The curve for the single 2N3904 is shown below.

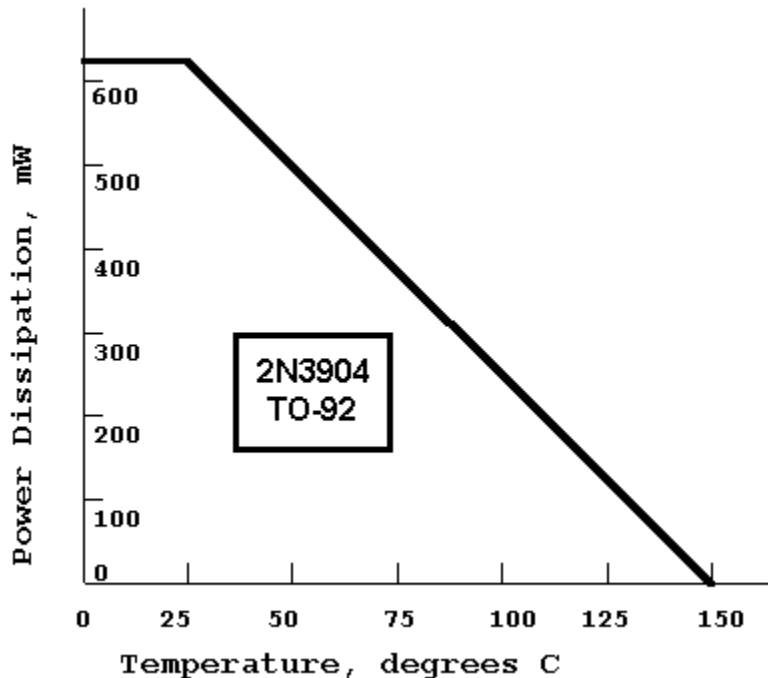

Other parameters are also significant, an important one being thermal resistance, R_{θ} . The 2N3904 has a thermal resistance, $R_{\theta JA}=200\text{ }^{\circ}\text{C/W}$ indicating a junction temperature rise of $200\text{ }^{\circ}\text{C}$ for each watt dissipated in the transistor. The "JA" subscript indicates that this value describes the temperature difference between the junction and ambient, the surrounding air in this case.

We have a dynamic situation here. As the above figure shows, the allowed power dissipation drops with increasing temperature. But the dissipation of power causes the temperature of the junction to increase above the ambient temperature.

Assume a key down PA efficiency of 50%. (It's typically better than this.) So, if the TX output is 0.6 watt, we will dissipate an identical amount in the form of heat. Half of this will occur in each transistor, 0.3 watt per device. The junction temperature is then 60 degrees above ambient. The ambient around the transistor is generally going to be at or below $50\text{ }^{\circ}\text{C}$, putting the junction at 110

° C. A plastic transistor will survive with junction temperatures of up to 150 ° C. But this temperature is 80% of the way between room (25 ° C) and 150 ° C, so the rated dissipation is down to 125 mW. So, the 2N3904 is indeed beyond rating for this extended key-down operation.

We do not expect to hold the key down continuously. A worst case realistic stress might be a string of dits with a 50% duty cycle, resulting in 150 mW per device and a predicted junction temperature rise of 30 ° C. If ambient is still 50 ° C, the junction is at 80 ° C where the rated dissipation is 350 mW. We are safe with a pair of 2N3904s operating at this power level. However, a continuous key down situation should be avoided. (I have had no practical problems at all with this design or other amplifiers with a pair of 2N3904s at a similar power level. See the discussion of duty cycle in Ch 12 of EMRFD mentioned above.)

We might encounter problems if we tried to push the 2N3904 pair to significantly higher power levels with our 12 volt power supply. Not only would we encounter thermal stress but might exceed the 200 mA maximum current. The present current (at 0.6 watt TX output at 50% efficiency) is that corresponding to an input power of 1.2 watts, 100 mA average for two transistors with a 12 volt supply. But the peak current will be higher than this 50 mA per device average. It would be 100 mA per device in an idealized amplifier, and is probably even higher for part of the cycle if drive is high. It could be much higher if we were seeking high efficiency. A one watt output would probably exceed the limits of the 2N3904 pair. The better design would add parallel devices, or go to a more robust transistor. Note that the 2N2222A has a much higher maximum current than the '3904.

Clearly, we can actually design the circuit, including an evaluation of the thermal performance. It is not necessary to rely on mere lore. Lore can offer guidelines in the absence of science, but we are more fortunate than that. Take a look at the thermal performance discussion in the power supply section of Horowitz and Hill's outstanding volume, "The Art of Electronics." (Cambridge University Press, 2nd Edition, 1989.) I recommend this text over any other I have ever encountered for anyone interested in electronics, at any level from high school to graduate student. (What more can I say in the way of an even stronger recommendation?)

There is another option available to the builder. The cost of a 2N3904 is a mere nickel. You may have to buy 100 of them at a time to get this price, but that is still a outstanding investment. At this price, it is worth testing, even to the point

of destruction. So, build a half watt transmitter, adjust it for the desired output and measured collector current, and test it under extended key down conditions. Again, we resort to science, but now with an experiment performed by the builder. Either approach is preferred over a blind adherence to lore!

A really useful sidebar to this discussion occurs when we extrapolate the general problem to Surface Mount Technology. A SOT-23 version of the 2N3904 is readily available and we would certainly be tempted to build this transceiver in SMT form. After all, all of the components used (except for toroids) are available in SMT form. The thermal properties of the SMT versions are significantly different, but are well specified by the manufacturers. Generally, the collector dissipation of a SMT part is reduced because the device size is so small, but can be extended by using large collector tabs on the circuit boards. A general rule of thumb is perhaps 150 to 200 mW at 25 ° C for a SOT-23. The SOT-89 and other larger variations are preferred for higher power. The 2N3904 is available in both sizes. (We can do thermal measurements of those collector tabs to add science to that lore.)

The 20 Meter Band

Some builders have already expressed interest in the 20 meter band. Here are the values that we used in the one that we assembled:

C2 and C90=100 pF, C1=100 pF (but experiment yourself!), C3=33 pF, T1=21 t #30 on a T30-6 with a 4t link of #22, L1 and L2 = 4.7 uH RFC, C12=5-65pF trimmer, C13=220 pF, C14=440 pF (two parallel 220), C15=270 pF, L3= 940 nH (15t#26, T30-6), L4=757 nH (14t#26, T30-6), L5=1 uH, 16t #26, T30-6, C19=68 pF, C18= 22 pF.

The 6 Meter Band

I ordered a crystal for 50.125 MHz in the very beginning with the intention of getting the details worked out immediately. Well, I finally got around to it!

Oscillator: C2=10 pF, C90 not used. C1 is 10 pF for a 1 kHz shift, but will depend on crystal. C3 is not used. T1: 11 turns #28 on a T30-6, 2 turns #22 for output link.

Driver: R14 was 0 in this rig.

PA: L1=2.7 uH RFC; L3=280 nH, 9t #22 on T30-6; L4= 212 nH, 8 t #22 on T30-6; C13=47 pF; C14=120 pF; C15=68 pF; C12 = 2-18 pF trimmer; L2= 1.1 uH, 20t #26 on T37-6; Q5 and Q6 replaced with a single 2N4427; R19 not used; R18= two parallel 6.8 Ohm resistors.

Receiver: C19 not used. C18= 6.8 pF ; L5 = 290 nH, 9t #22 on T30-6.

The 2N4427 provides about 400 mW output on 6M. The pair of 2N3904 could only be pushed to about 250 mW without increasing current in Q3, the driver transistor. But the present current is pushing 30 mA. If higher current in this stage is planned, a TO-39 device is suggested.

There seems to be no accepted QRP frequency for the 6M band. 50.060 is probably a poor choice, for it is in the middle of the part of the band used for beacons. 50.125 is useful as a calling frequency in the western US, although it will certainly antagonize some of the DX operators. My present inclination would be something just below 50.100 MHz, perhaps '098 or so. Comments would be appreciated !

The 30 Meter Band

This is some data developed by Bill Kelsey, N8ET, At Kanga US. He built versions for 40 and 30 meters very early in the process. I have not yet to built one for 30.

C1: 56 pF, C2,C90: 270 pF, C3: 56 pF, C4,C20: 4-65 pF, C12: 22 pF, C13: 270 pF, C14: 560 pF, C15: 330 pF, C18: 47 pF, C19: 120 pF, L1,2: 12uH, L3: 17t, T37-2, L4: 15t, T37-2, L5: 18t, T37-2.

T1: 25t on T37-2, 3t secondary, T2: Same as other bands.

Regarding coils: We shifted around from one toroid to another for the various bands that we built. The cores used are usually dictated by what is available in the junk box. Obviously, one can use other parts and we encourage you to experiment. We started with the T30-6 because we had several available at the time of building.

A New 7 MHz Variation 20 Jan 04

We recently built yet another version of the Micromountaineer, and yet another for the 40 meter band. But this one had a few refinements. The rig included four built-in crystals, selected by a junk box two-pole multiple position switch. The AIT function was retained. A center off type ON-OFF-ON Toggle switch allowed three different VXO capacitors to be inserted. The overall result was a system with 24 discrete frequencies.

A TICK-4 Keyer (now available from Kanga) was included in the box. We use a traditional non-iambic paddle, which functions fine with the TICK with no changes.

Finally, we added a passive LC filter (N=3) to the audio output.

The circuit modifications are shown below:

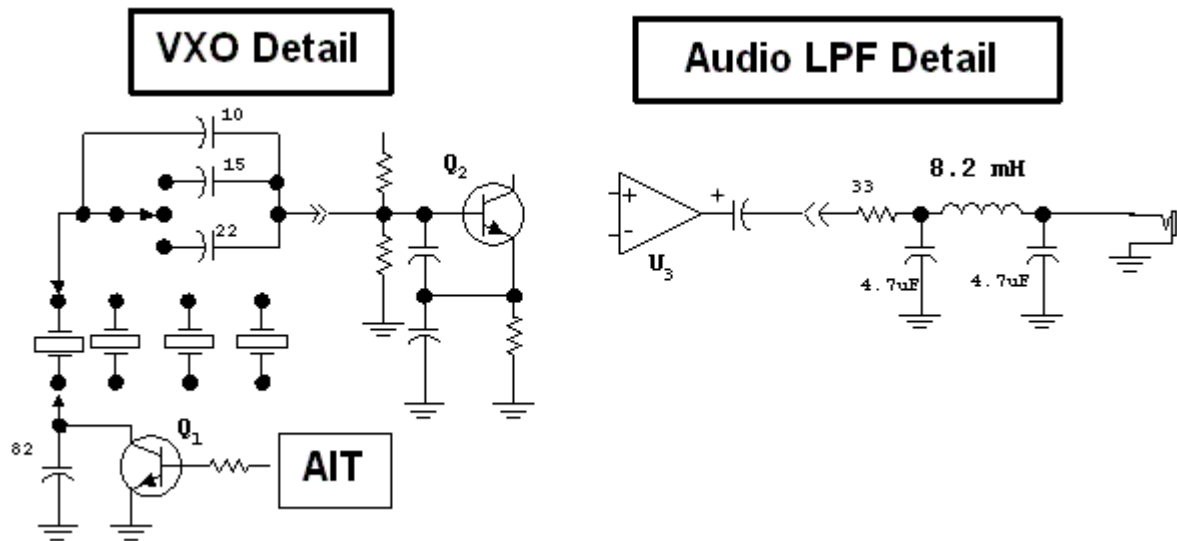

There is a lot of flexibility and room for experimentation here. The individual experimenter may need to change the VXO capacitors to hit the desired range. The audio filter is designed for a 1 kHz cutoff with a 35 Ohm source and load. But slight changes in L or C won't upset things badly, so use what you have available.

I used crystals marked for 7030, 7038, 7040, and 7042 kHz. The measured

output frequencies are presented in the following figure:

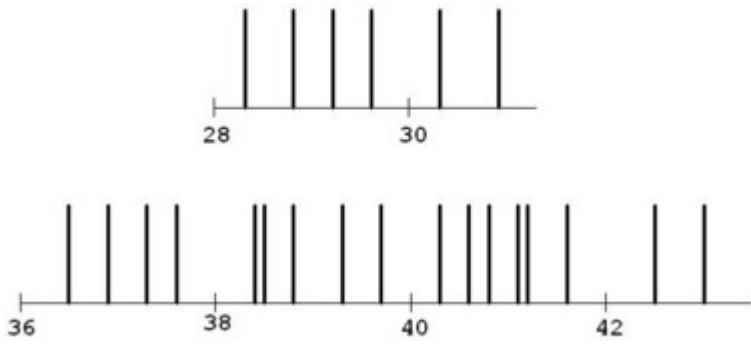

A VFO would still be preferred, but the stability of crystal control along with the sleeping bag compatibility (from inside, that is!) of the rig justifies the choice. Now to see how it does in the hills.



The transceiver is packaged in a 1 x 3 x 8 inch plastic box from Radio Shack, producing a transceiver weight of 8 Oz.

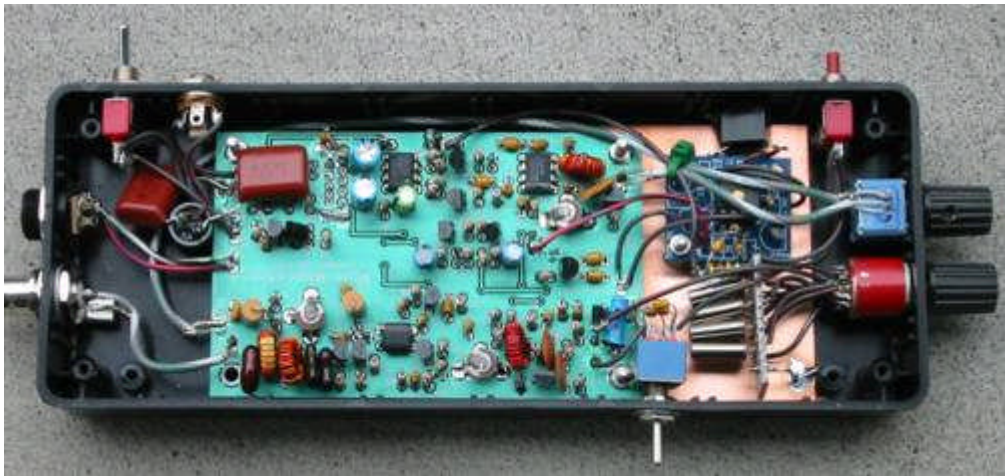

view. Inside

Increased Power. 24Sept06

The half watt level has been a good choice when battery consumption is an issue. However, a bit more power is useful when in the field with a desire to make contacts quickly. To this end, I thought I would increase the output of the backpackable version of the Micromountaineer shown above. The parallel 2N3904 transistors were removed and replaced with a single power part, a 2SC5739. This part is a gem; it's cheap but is still robust. See QST, April, 2006. The new circuit is shown below.

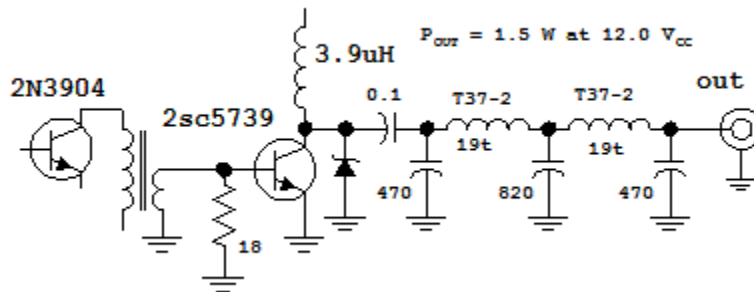

The RFC was replaced with one with a smaller inductance of 3.9 uH. The output network was redesigned to be a simple Chebyshev, then altered to an ultraspherical form to fit capacitors in the junk box.

The inductors in the filter are 1440 nH, one on a T37-2 core with the other on a T37-6. The -2 data is shown. The initial application of DC to the circuit yielded more power than we really wanted at 12.0 volts, so the base resistor was dropped to 18 Ohms. This produced an output of about 1.5 Watts with $V_{cc}=12$, increasing to about 2.5 Watts with $V_{cc}=13.7$. The transceiver draws about 20 mA during receive (with headphones and low signals). At $V_{cc}=12$ volts and an output of 1.5 Watts, total transceiver efficiency is about 50%. The PA seemed to run cool. However, I thought it worthwhile to include a heat sink. A strip of brass was bolted to the 2SC5739 and then soldered to the circuit board. This is shown in the photo below.

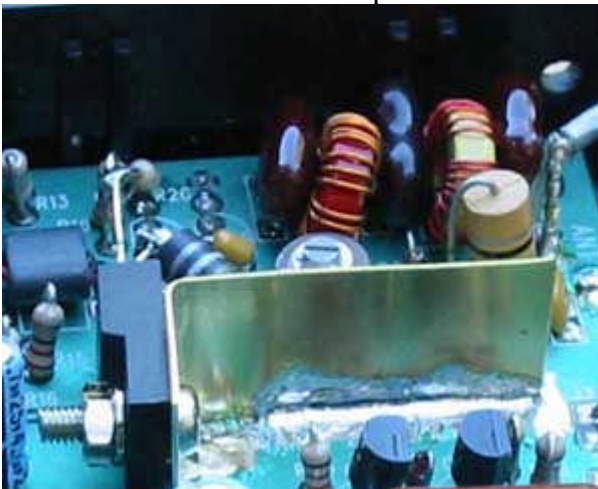

Heat sink Detail.

The rig works well in the home environment. Now to get it into the field, perhaps in the coming winter on a snowshoe trek.

Click here to return to [W7ZOI home page](#).