

Additional Measurements on the EMRFD *First Transmitter*

w7zoi, 23August07

Chapter 1 of Experimental Methods in RF Design (ARRL, 2003) features a simple transmitter design with the purpose of illustrating some of the design and measurement procedures. The treatment presented is restricted to just a few data points. However, some comments in the text suggest that other instruments may be used. In this report we present the results of having examined the circuit with three instruments:

1. A DC volt meter.
2. An RF Probe driving a DC volt meter.
3. A high speed oscilloscope with a 10X voltage attenuator probe .

RF Probe Calibration

The first part of the experiment is to calibrate the RF probe. This was done with a calibrated signal generator. This is illustrated with Fig 1.

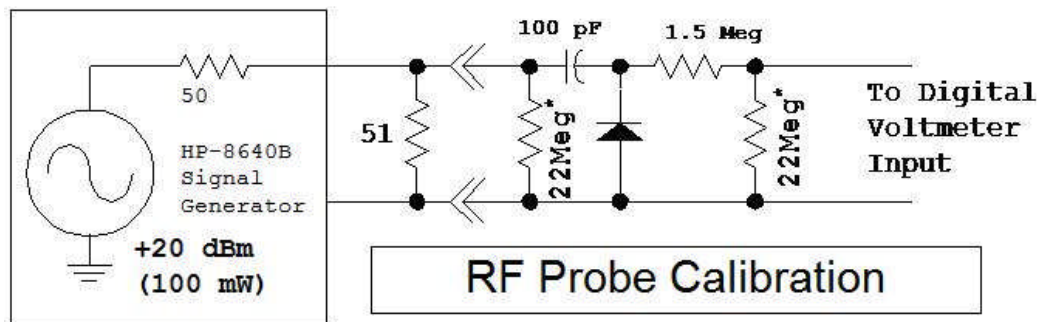

w7zoi 23August07

1. Set Generator for 100 milliwatts output.
2. Terminate Generator with 50 Ohm load.
3. With this power, $V_{out} = 2.236$ volts, RMS
4. This is 3.16 V peak, or 6.33 V peak-to-peak.
5. We measured 2.54 volts with the RF probe and DVM. This is a lower than the peak because of the 1.5 Meg in the probe.
6. The actual peak will be the measured DC multiplied by the factor $3.16/2.54$, or 1.244. Had we used a larger R instead of the 1.5 Meg, we could have forced this factor to be one.
7. We measured the voltage with an oscilloscope and 10X probe and got 6.3 V peak-to-peak.

*. The 22 Meg resistors are used as stand-off instulators and have little to do with the operation.

Fig 1. The procedure used to calibrate the RF Probe.

We started with 100 mW applied to a 50 termination from a lab quality signal generator. This generator had been recently calibrated against a HP Power meter, enhancing our

faith in a modicum of accuracy. With the generator set of 100 mW output into 50 Ohms, we solve to obtain the voltage. The various relationships are standard and won't be repeated here.

An oscilloscope was attached to the load to confirm what we had calculated. The agreement was nearly exact.

We then attached the RF probe, which is the one that is presented in EMRFD Figures 1.29 and 1.30. It is nothing more than a peak reading rectifier that drives a high impedance volt meter. We used a Fluke Model 73 DVM for our measurement, although this is not critical.

We determined that the peak RF voltage will be given by

$$V_{\text{peak}} = K \cdot V_{\text{DC}}$$

where the calibration constant for our probe was $K=1.244$. Hence, when we see 1.3 volts on the DVM, the peak RF voltage will be 1.62 volts. This assumes that the signal is a sine wave. That may not be a valid assumption.

Calibration with a Transmitter.

Not all experimenter have a good signal generator. We can still calibrate our RF probe by using an available source of RF. This is shown in Fig 2.

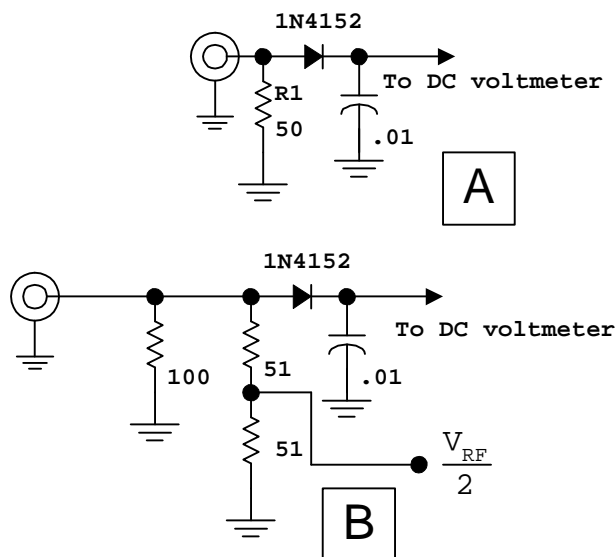

Fig 2. Calibration of an RF Probe with a Transmitter. See Text.

We will illustrate calibration with an example. Let's say you have a transmitter with an output somewhere around 2 Watts. Attach the rig to the power meter in Fig 2A and press the key. Assume that the circuit is interfaced with a DVM and that when you press the key, a response of 16.0 volts is observed. A silicon diode is used in the rectifier and this

will have a voltage drop of around 0.5 volt. (It would be more if the meter was not such a high impedance. Most Digital Voltmeters have a 10 Meg input resistance.) So the peak RF voltage will be 16.5 volts. The power is just

$$P = V_{\text{peak}}^2 / (2 \cdot R_{\text{Load}}) = 16.5^2 / 102 = 2.67 \text{ Watts.}$$

Actually, we don't even need to know the power. The 16.5 volts is the important parameter. If we now attached the RF probe to the hot end of the 51 Ohm load, we will see a response in the DVM attached to the probe of 13.3 volts. From this we calculate a calibration constant of $16.5/13.3=1.24$, which is essentially what we determined earlier.

There is a problem that we must take into account: The diodes we often use in RF Probes are often low capacitance, low current types that often have a low breakdown voltage. The diode used in the detector of Fig 2A will have 33 volts across it when the RF signal is at the negative peak of the sine wave. This is higher than the usual Silicon hot carrier diode, or Germanium diode such as the popular 1N34A. A safer procedure to use is shown in Fig 2B. In this case, part of the termination is a series connection of two equal resistors. Hence, the voltage at the tap will be half that across the whole load. In this case, we will have a peak voltage of 8.25 volts at the tap. This value can then be used to calibrate the RF probe.

(The data presented in connection with Fig 1 resulted from the actual measurements described. But I fabricated the data related to Fig 2 to illustrate the procedure.)

Measurements on the *First Transmitter*.

Having calibrated the RF probe, we can now use it to study the circuitry used in the First Transmitter discussed in Section 1.11 of EMRFD. The first set of measurements I wanted to do was just to look at the DC biasing. A 51 Ohm termination resistor was placed on the output of the low power part of the transmitter. I then removed the crystal, which gets rid of any RF. The RF will alter the DC levels and complicate DC measurements with the usual DVM lead.

The circuit of the first three stages is presented in Fig 3. The DC levels that I measured with the DVM are presented in the ellipses.

After marking these values on a schematic in my notebook, I re-attached the crystal so I can measure RF levels, first with the RF probe, and then with an oscilloscope.

The measurements that I took with the RF probe occurred throughout the circuit. The values are shown inside a hexagon and are just the DC values that appeared on the DVM. You can multiply them by the calibration factor to obtain peak values if desired.

