

Retuning Meshes in a Lower-Sideband-Ladder Crystal Filter

Wes Hayward, w7zoi, 2September2018

The most common form of crystal filter we encounter in SSB/CW communications is the lower-sideband-ladder. An example with 4 identical crystals is shown below.

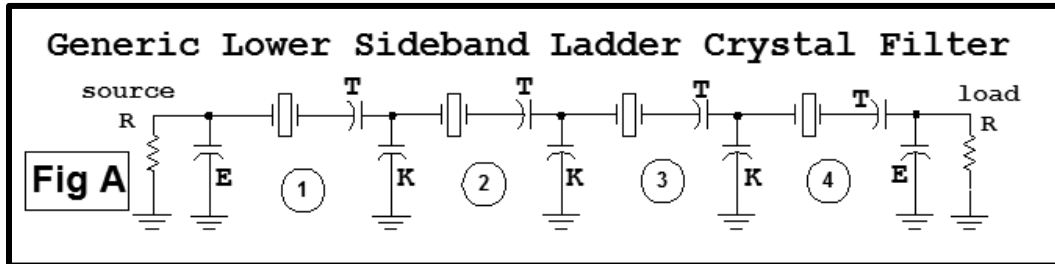

The capacitors marked with E in the figure transform the source and load resistors to lower resistance to properly load the end meshes, 1 and 4 in the example. The three capacitors marked with K (not all identical) serve to couple energy between adjacent resonators. While crystal characteristics dominate, the resonant frequency of a mesh with a crystal is altered by all components in that mesh. The four series capacitors marked with T (again, not all identical) are a handle to tune the individual meshes.

The problem

But there is a problem. Experimenters often build a filter using available design software and parts only to discover that the filter is not at the desired frequency. Fortunately, it is possible to move a filter upward in frequency by changing the tuning capacitors, T in Fig A. The retuning procedure is the subject of this note.

Crystal ladder construction usually begins with a batch of crystals from a single source. The crystals are measured to catalog their series resonant frequencies and to establish model parameters. Frequency measurements match crystals, usually to within 10 or 20 % of the bandwidth of the filter that will use them. Motional capacitance is directly related to motional inductance, so it is not an independent variable. The design process generates the coupling capacitors and the end capacitors, K and E, leaving mesh tuning as the final step.

The tuning capacitors, T of Fig A, are often calculated in the filter design process. Alternatively, the tuning can be done with special computer programs. The following figure shows one such program, Meshtune.

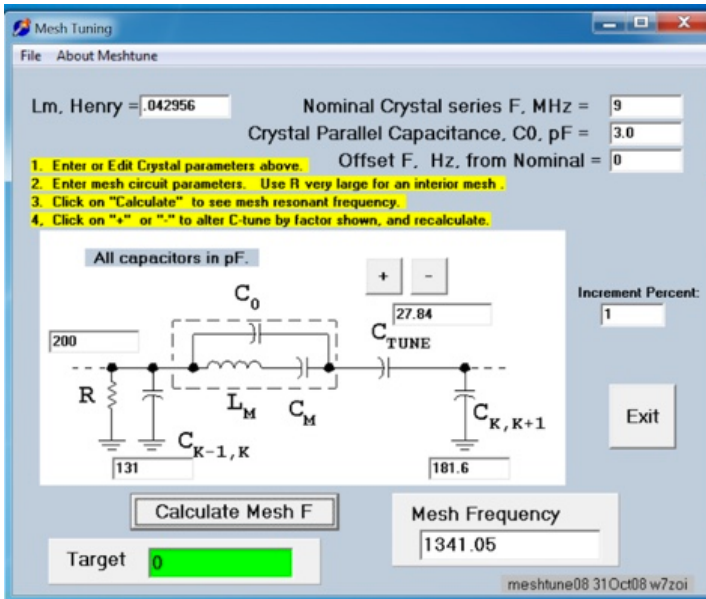

This program will allow meshes to be tuned above an initial frequency and will accommodate crystals that are offset in frequency from a group.

An Exact solution.

The tuning problem can be addressed with an analytic solution without computer analysis. Equations are first written to evaluate mesh frequencies based upon measured crystal parameters and filter design capacitances. The equations can then be solved for the tune capacitance as a function of mesh frequency. This is the basis for the rest of this note. The calculations are not difficult, so the details of solving the equations will not be presented. We will, however, show the procedure used to calculate resonance.

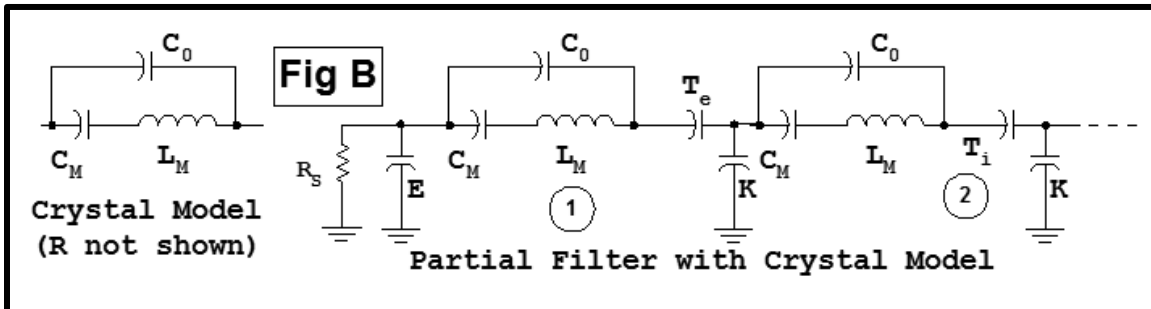

Figure B shows a crystal model. That model is then inserted into the filter. We only show two meshes, for that completely encompasses the mesh tuning problem. This analysis is easily extended to $N > 4$.

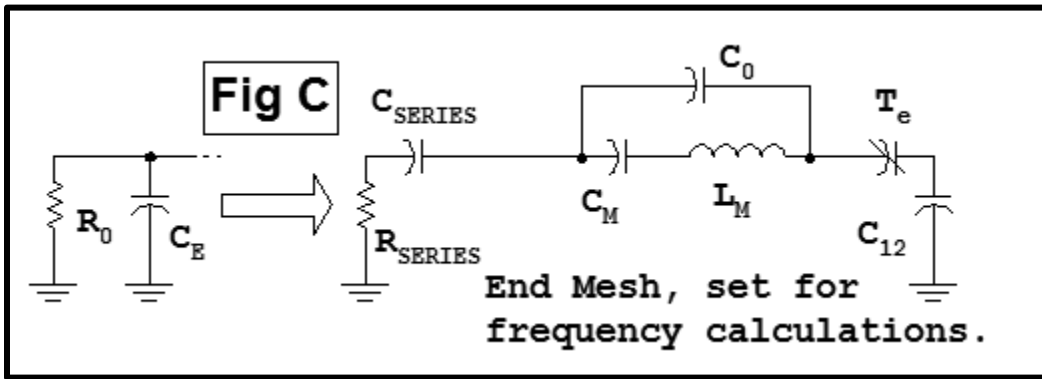

Fig C shows a mesh at one end of the filter. The parallel load resistance, R_0 , along with the shunt capacitor C_E , is transformed to an equivalent series circuit. The series capacitance, C_E , is then used in the resonance calculation.

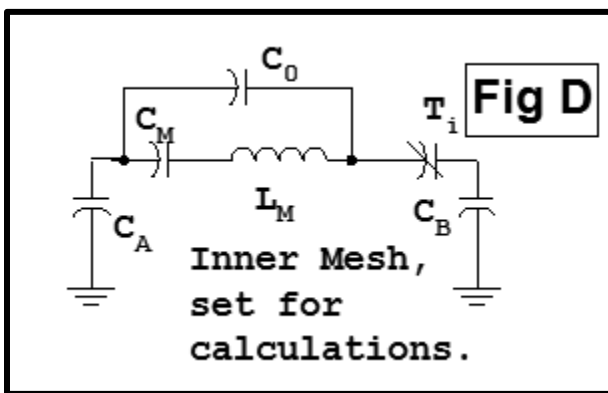

Figure D shows an interior mesh. The tune capacitors in Figures C and D are shown as variables, for these are the parts that will be adjusted to set the mesh frequencies. The equations for an inner mesh also analyze an end mesh using a series C rather than one paralleling the termination.

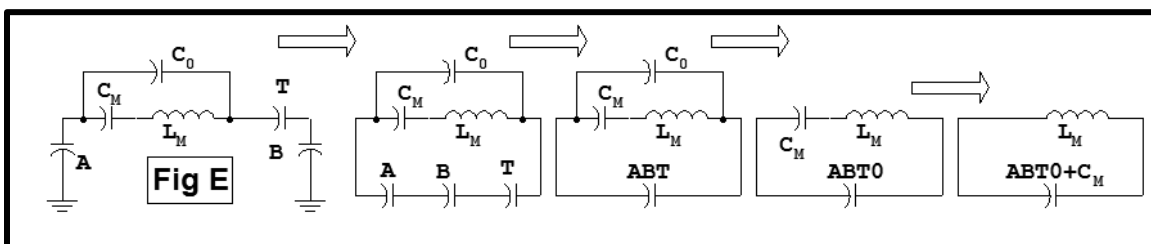
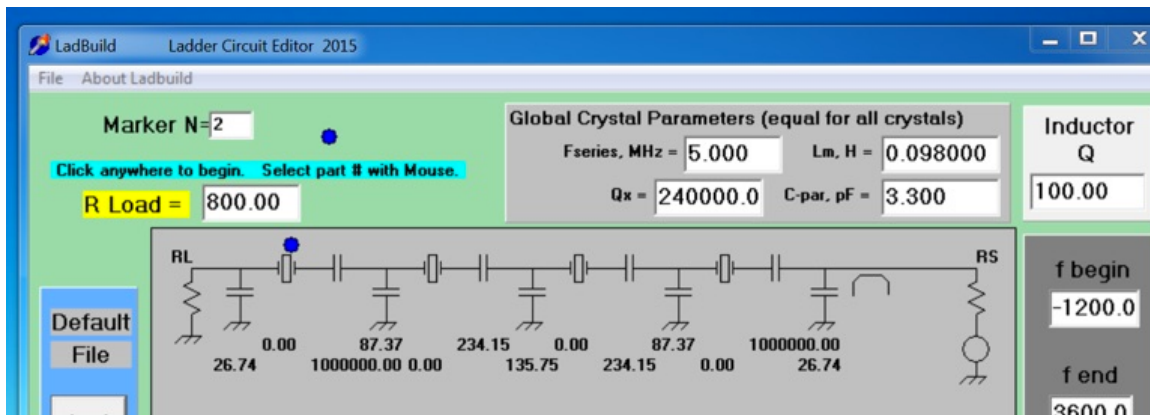

Figure E shows a progression of calculations. The ground symbol is eliminated, with the ends of capacitors A and B attached together. These are in series with the tune capacitor, T, to form ABT. This capacitor is in parallel with the crystal “holder” capacitance, C_0 with that combination now defined as ABT0. This is in series with the crystal motional element, C_m . This leaves a simple series LC which can now be used to calculate resonance for an inner mesh. The end mesh resonance calculation is similar. We assume the reader is familiar with two capacitors in series and the equivalent C.

The results of the Fig E exercise are equations for frequency expressed as a function of independent capacitances and the motional inductance, L_m . These equations are solved for tune capacitance with frequency as a parameter.

A Design Example

The equations will be presented below and will be illustrated with a design example. A $N=4$ Butterworth filter was designed for a bandwidth of 600 Hz. The crystal frequency was 5 MHz. These junk box HC-49 crystals had excellent measured unloaded Q .



This figure shows the schematic for the basic filter. The series tuning capacitors were calculated by XLAD, the program used to design the filter.

Frequency before Retune

The beginning mesh frequencies must be known before retuning. These can be calculated with the equations derived from the procedure presented in Fig E above. The above schematic includes the crystal parameters. These are used with the capacitance values to calculate the mesh frequencies. The formulas used for an **interior** mesh are presented the following box.

$$C_i = \frac{1}{\frac{C_{Bi}^2 + C_{Ai}^2 + C_{AB}^2}{(C_{AB}C_{Bi} + C_{OBi} + C_{OAi} + C_{OAB})} + 4\pi^2 f_s^2 L_m}$$

C_i is the capacitance that will resonate with L_m to determine the inner mesh frequency, f_i . It is useful to calculate the difference between f_i and f_s , Δ_i .

$$f_i = \frac{1}{2\pi \sqrt{L_m C_i}}$$

$$\Delta_i = f_i - f_s$$

C_A and C_B are the coupling capacitors and T_i is the tuning capacitor. C_0 is the crystal parallel capacitor. C_E would replace C_A for the special case of an end mesh with a series load capacitor. Result C_i is the net capacitance in series with the motional inductance, producing a mesh resonant frequency f_i . This is compared with the series resonant frequency to yield a difference, Δ_i . Inserting the parameters for the filter in the schematic shows that the interior meshes resonate at 554.4 Hz above the series frequency.

A similar exercise evaluates the **end** meshes, shown in the following box.

$$C_{ser} = \frac{C_E^2 (2\pi f_s)^2 R_0^2 + 1}{C_E (2\pi f_s)^2 R_0^2}$$

This series capacitance replaces C_E in the tuning process. Net END mesh frequency is then.

$$C_e = \frac{1}{\frac{C_{ser} T_e + C_k T_e + C_k C_{ser}}{(C_k C_{ser} T_e + C_0 C_{ser} T_e + C_0 C_k T_e + C_0 C_k C_{ser})} + 4\pi^2 f_s^2 L_m}$$

This C_e net end capacitance resonates with L_m to determine the resonant frequency of the end mesh.

$$f_e = \frac{1}{2\pi \sqrt{L_m C_e}}$$

$$\Delta_e = f_e - f_s$$

This calculation resembles that of the inner mesh except that the series capacitor C_{ser} must first be evaluated. If the original parallel C_E was used, errors would result owing to shunting by the resistance. The series form has all end current flowing through the capacitor. A tuning capacitor of 1 uF is shown in the filter schematic. This high value (1000000 pF) is effectively a short circuit. The resonant frequency for this end mesh is also 554 Hz above crystal series resonance.

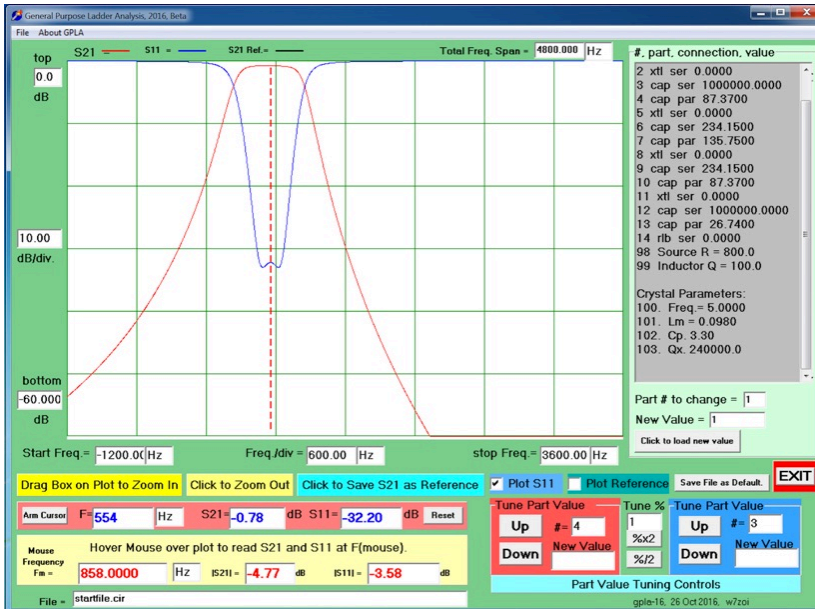

This figure shows the calculated response for the filter. A cursor at 554 Hz shows that the filter is tuned as predicted by the above calculations.

Retuning

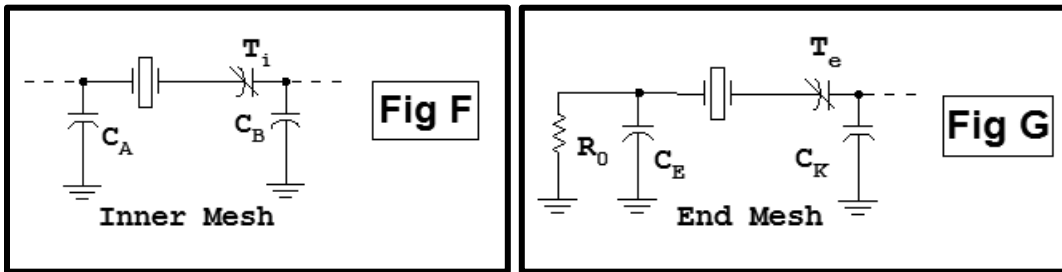

Figures F and G show both meshes within a filter. The following blocks illustrate the calculation of the tuning capacitors to a new, higher frequency.

The first data is for the crystal and filter termination. All crystals assumed identical.

$$f_s = 5 \cdot 10^6, L_m = 0.098, C_0 = 3.3 \cdot 10^{-12}, R_0 = 800$$

Next, we enter the offset frequency with respect to the series crystal frequency, f_s .

$$\Delta = 1054$$

The offset Δ of 1054 was picked, for it is 500 Hz above the original mesh frequency of 554 Hz with respect to the 5 MHz series frequency.

The following capacitors, CA and CB, are for an inner mesh.

$$C_A = 87.4 \cdot 10^{-12}, C_B = 135.8 \cdot 10^{-12}$$

The following equations then determine the tuning capacitor for the mesh.

$$f = f_s + \Delta$$

We define a dummy variable W, used for both end and inner mesh calculations.

$$W = \frac{(f^2 - f_s^2)}{\left(\frac{1}{4\pi^2 L_m} - C_0 f^2 + C_0 f_s^2 \right)}$$

$$T_{\text{inner}} = \frac{1}{W - \frac{1}{C_A} - \frac{1}{C_B}}$$

$$T_{\text{inner}} = 3.5312e-11$$

The inner mesh is tuned to 1054 Hz above fs with 35.3 pF.

The following box shows the retuning of the end mesh of the example filter.

Now enter capacitor CE and CK for an end mesh.

$$C_E = 26.7 \cdot 10^{-12}, C_K = 87.4 \cdot 10^{-12}$$

$$T_{\text{end}} = \frac{1}{W - \frac{C_E^2 4\pi^2 f^2 R_0^2}{C_E^2 4\pi^2 f^2 R_0^2 + 1} - \frac{1}{C_K}}$$

$$T_{\text{end}} = 4.15789e-11$$

The tuning capacitors for the end meshes are 41.6 pF, bringing the filter frequency to 1054 Hz above the crystal basic series resonant frequency. Placing $\Delta = 554$ Hz in the equations will result in a very large tune C in the end mesh and an inner tune capacitance of 234.2 pF.

The above equations were used to move the filter for an additional 500 Hz to a frequency of 1554 Hz above fs. The response for this retune is shown below.

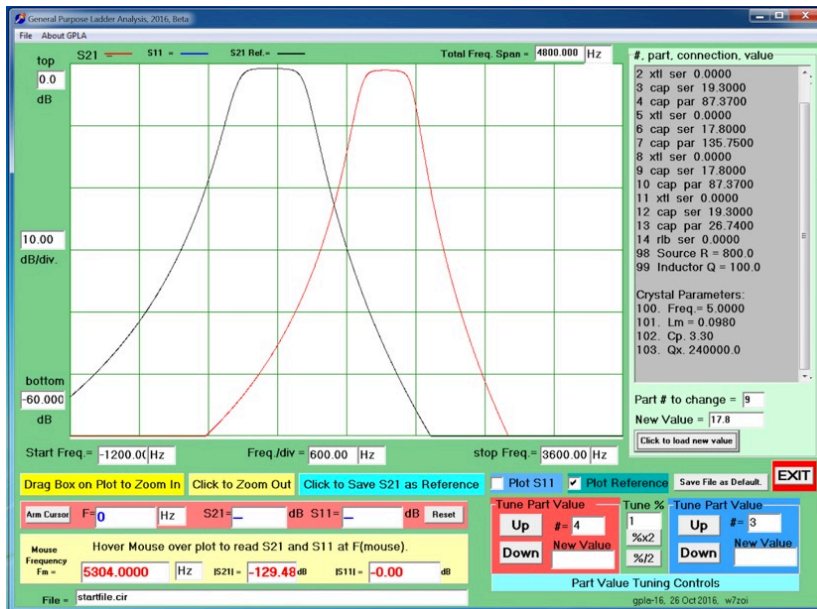

The initial $\Delta = 554$ Hz response is shown in black with the retune to 1554 Hz in red. Component values are in the table at the right side of the figure. The center frequency changes by the desired 1 kHz. However, the filter bandwidth is lower and the insertion loss (IL) has increased. The change in IL will be more extreme if lower Q crystals had been used for the filter. The $\Delta = 500$ Hz curve would be between the two shown.

Final Thoughts

The Lower Sideband Ladder filters can be retuned to a higher frequency by changing the tuning capacitance in each mesh. This is most useful for relatively small changes. The 1 kHz example shown here is extreme. Meshes can also be moved downward by inserting inductance, although this can be difficult. These retuning methods, including both Meshtune and these calculations, are independent of the method used to initially design the filter.

The synthesis method used to design the filter discussed used a perturbation method described in **Experimental Methods in RF Design** (ARRL 2003, W7ZOI, KK7B and W7PUA) and references cited. This method is the basis for the software distributed with **EMRFD**. The method does not specify a center frequency during design. Design at a specified frequency can be performed with the methods of M. Dishal, "Modern Network Theory Design of Single Sideband Crystal Filters, Proceedings of the IEEE Vol. 53, No. 9, September 1965, pp1205-1216.