

# Simple Improvements to a Simple Receiver

Rick Campbell 24 April 2008

The simple receiver circuit presented on pages 8.4 - 8.6 of EMRFD has been widely duplicated and used as a starting point for many experiments. As with any receiver design intended to be built using available components, each version is different. A recent exercise resulted in several improvements to the ugly constructed receiver in the photograph in the upper left corner of page 8.4.

This is the actual schematic diagram of the receiver in the photograph. It differs slightly from the schematic in the book, but is essentially as described in the text. Critical listening revealed weak audio, as expected, and lots of high frequency noise and signals. When operated using a bench supply instead of a 9v battery, there was some tunable hum.

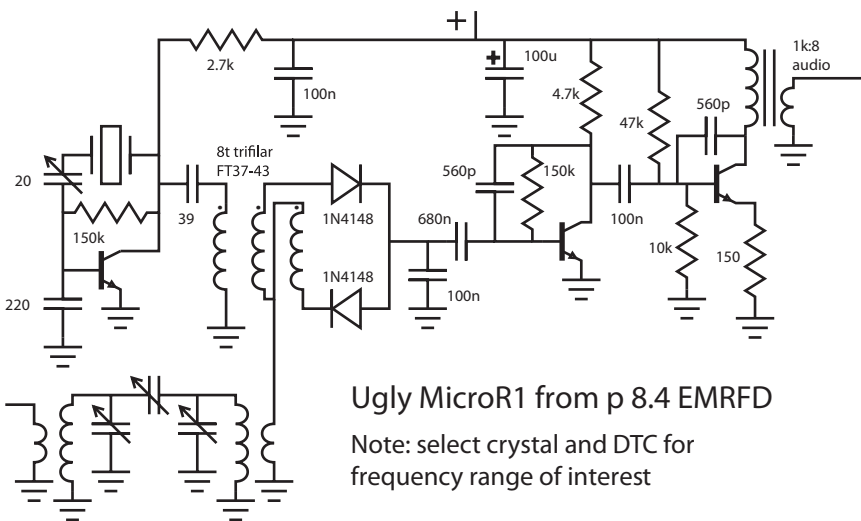

The minor changes to the circuit may be seen in the schematic to the right. A simple low pass filter restricts the audio frequency response to a range useful for CW and SSB. The 560pF capacitor was removed from the first transistor audio stage, because it didn't seem to do much.

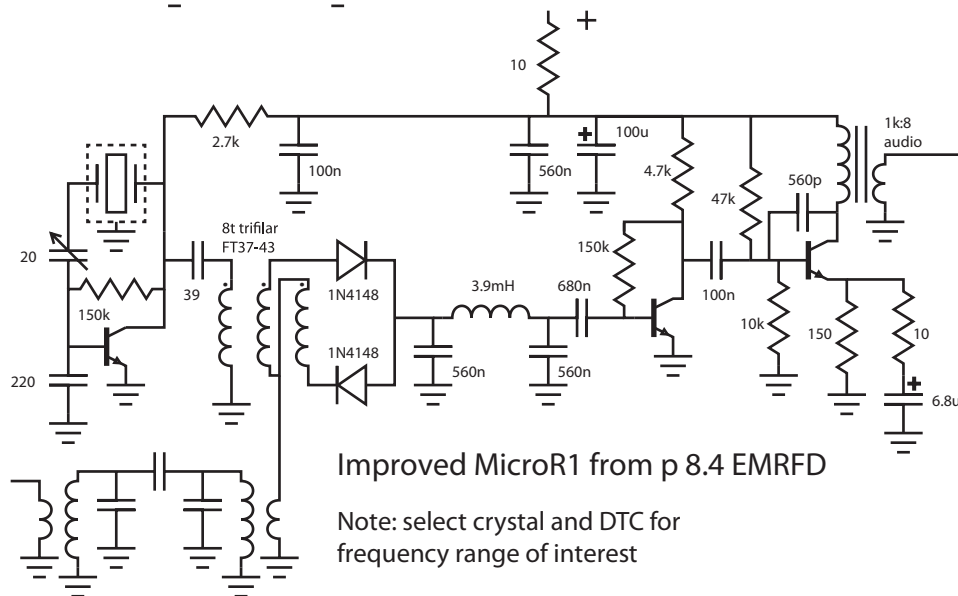

Restricting the audio bandwidth allows more gain, so the AC emitter bypass was added to the output stage. Additional power supply decoupling eliminated most of the tunable hum, and soldering a short wire from the crystal can to ground eliminated the rest. After tuning the input double tuned circuit, the variable capacitors were removed, measured, and replaced with fixed capacitors. This permits a more compact layout. The final receiver is built ugly style on a 1.3" by 3.2" board, and is delightful to listen to.

Here is a photo of the completed receiver in its natural environment, sitting on the backyard picnic table. A Uniball pen is for scale comparison. The receiver is simple, small, and draws 8 mA from a 9 volt battery, but hears signals from thousands of miles away when connected to a half-wave dipole antenna 30 feet up.

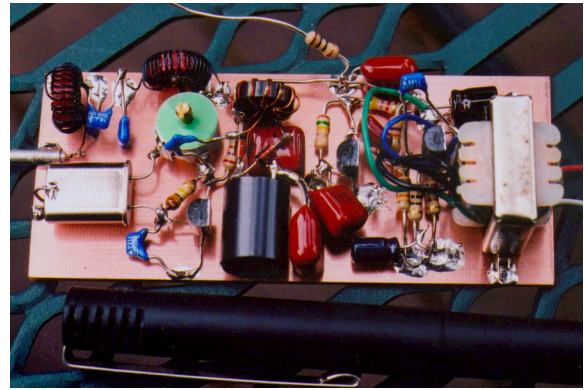

Here is a detail shot of the RF, LO, and mixer. The mixer in this application is often called a “Product Detector.” The antenna input is the small coax soldered to the board at the left. The simple Pierce oscillator with 7.030 MHz crystal and green trimmer capacitor are on the lower left part of the board. The product detector with its trifilar toroid, two diodes, and bypass capacitor are in the upper right. The audio low-pass inductor is the gray cylinder on the bottom right.

Here is the detail shot of the product detector and audio section. The gain is low enough that there is no need for a volume control, even though the band noise is clearly audible in the headphones. One simple way to implement a volume control would be a 100 ohm variable resistor directly across the headphone jack. That varies gain by reducing RL for the output stage.

